

**IDENTIFYING AND SOLVING OPTIMIZATION  
PROBLEMS ON INTERNET\***

**Miguel A. Garay Garcell, Liz Y. Martínez Delgado,  
Leydier Arguelles Torres, Ariel Castellanos Isaac**

*Havana Institute of Technology, Cuba*

*Represented by a Member of the Editorial Board Professor V.I. Konovalov*

**Key words and phrases:** identifying; Internet; optimization.

**Abstract:** Model design and implementation by means of computer technology and methods has been a focus of multiple researches in Artificial Intelligence, Operations Research, Decision Support and Management Systems at the last years. At the present paper, it is proposed a new approach based on application of systems approach, knowledge based systems, case based reasoning, and e-learning in model building. Here, the problems associated to construction of optimization models by means of computer are discussed from theoretical and practical point of views. Finally, a new hypermedia intelligent system on Internet is proposed. It has as objectives to help learners (professional and students) in model building and implementation. Taking into account this conception a new e-learning platform for Operations Research's teaching and learning was developed. The system has been implemented in **net** technology using **C#** computer language and **web services**. At the present time, it has been testing and improving at Havana Institute of Technology.

---

**Introduction**

One of the main and most complex problems in OR learning is associated to model building. Since ancient times, models have become widely accepted as a means for researching complex systems. However, the cognitive processes involved in the model building continue being a complex and ill-structured problem. Like Wagner [3], has argued: «**Model design is the essence of Operations Research**». In spite of this brilliant idea, nowadays continue without conscientious scientific research the problems associated with model formulation and implementation. This fact put in evidence, the actual gap between theory and practice in Operation Research. In model building we start constructing a verbal model for the real system. Then, it is necessary to refine the verbal model until it can be translated into a mathematical model. The real problem in translation arises when the initial verbal model is not an adequate description for the real system, and the defects of the verbal model are revealed in the attempt to translate. In other words, the verbal model lacks in some necessary attribute or characteristic

---

\* См. также статьи М.А.Г. Гарселла по математическому моделированию и интеллектуальным системам в Вестнике ТГТУ, 2002, том 8, № 2 и № 4 (примеч. ред.).

which must be discovered by researchers to develop the model formulation. These statements make evident two of the main problems on Mathematical Modeling:

1) the establishment of adequate relationships between the real system and verbal model (idealization process);

2) the translation from verbal model into mathematical model. In this relation arose the idea of developing an intelligent system for problem identification and solving by means of computer technology on Internet.

The designed system named ORWeb acts as a trainer helping learners in model building to acquire and develop modeling skills. Step by step ORWeb system takes you on an exciting session through the world of model building. You will see factories, cars and machines in moving. You will hear the motor sound, dangerous signals and advices. You will make complex decisions and develop modeling skills in model identification and selection the best algorithm for each decisional situation. The system has been implemented in .net technology using C# computer language and web services. At the present time, it has been testing and improving at Havana Institute of Technology. OPTIMAWEB system can be defined as a strong related set of informatics software tools and modules to increase the efficiency of the learning processes in Operations Research.

The acquisition of skills on idealization of real phenomena by students constitutes a complex and slow learning and thinking process. Ackoff said: «The quality of a model depends very much of the imagination and creativity of the research team. Intuition, insight, and other mental operations that are essentially uncontrollable play a major role in the process. It is not possible, therefore, to prepare a manual of instructions for model building. If such a manual could be prepared, it would be more likely to constrain than promote creativity. Nevertheless, when past experience in model building is examined, certain patterns emerge...» [1].

Model building is the most complex part of Operations Research. It is a considerable conceptual mistake to suppose that acquisition of modeling skills arises mysteriously through OR teaching and learning process. Commonly, the characteristics of idealization process are not well explained, as a powerful theoretical and practical method of knowledge acquisition. In order to solve efficiently complex Operations Research problems, it is necessary to acquire and develop skills on abstraction and generalization methods. However, the idealization process requires not only, to be able to do abstractions, but to be able to define the main and trivial variables.

In relation with the formulation problem Wagner said: «Surprisingly, it is difficult to write a verbal description of an OR problem that is completely unambiguous. More than once, thoughtful students have discovered vague wording in problems that had assigned previously to other classes that experienced no difficulty in obtaining the intended solutions. Many OR texts develop students' skills in translating a verbal model of a problem into an equivalent math model. For most students great difficult in solving OR word problem. The method used by most of these students is the memorization method. They read a problem quickly, and then search their memory in the effort to find an analogous problem that seems to be related to the problem. Once, they find it; substitute the parameters of the problem in the math model. For these students problem-solving becomes a matter of guessing and blind link [3].

Previous work in model management has investigated several important issues concerning model representation, integration and formulation. Liang (1993) has studied mechanisms for constructing larger models by integrating smaller ones. Murphy and Stohr explored the formulation of Linear Program using a graph based approach. Shaw et al discussed the application of Machine Learning techniques to the acquisition of model manipulation. Klir [22, 23] has developed the concept of «similarity» and system concepts. Hickman [6] has proposed an Expert System to identify an optimization problem.

All scientific works mentioned before have created conditions in order to develop a new theory on model building. Different methods can be applied to model management. At the present paper, we propose the use of Case Based Reasoning (CBR) for problem identification and solving. CBR methods and techniques have been applied to many domains in the last years. It is appealing because humans often make decisions in similar ways. In this relation, the main objective of the present paper is associated to Problem Formulation and Identification stages.

### Problem Formulation and Identification

The concepts of system, model and problem are closely related. At the present section will be develop the authors' conception and interpretation on these concepts and their application on modeling theory. Among the several formulated and used system's definitions at present time, there are some that appear more convenient for the present research than others, although of their different representation forms (Fig. 1).

**System definition:** System as beauty depends on researcher's point of view. In other words, the system representation is a function of interest, wishes and intentions of researcher. On this base, it is possible and convenient to define a system according to different point of views. Nevertheless, once have been defined the research interest in terms of objects, attributes and relations, it is possible to develop a rigorous analysis, according defined requirements. The scientific problem on relations between parts and whole continuing being an interesting problem in system theory: What is a part? ; What is a whole?; How many parts content the whole?; and other main questions constitute a great challenge for the scientific work. In his work title «The D'Alembert Dream» Diderot formulate interesting ideas on paradox between the whole and the parts. Inspired in Klir's system definition can be defined mathematically the concept definition of system [22, 23].

**Mathematical definition of system:** Suppose that a system  $S$  contains a set of elements, let be  $A = \{a(0), a(1), \dots, a(n)\}$ . Let  $a(0)$  be defined as the system environment. Each element of the system  $S$  can be characterized by a set of inputs and outputs. Let be  $r(i,j)$  a symbol that represent the relations between an element  $a(i)$  and an element  $a(j)$ . In this relation can be defined a set  $R$ , which contents the relations  $r(i,j)$ , where  $i = 0, 1, \dots, n$ ; and  $j = 0, 1, \dots, n$ . On this base, it is possible to formulate that: «A system is defined by the interaction between the elements belong to set  $A$  and the set of relations  $R$ , mathematically:  $S = \{A, R\}$ ».

Concept of model comes from Latin *modello*, *modus*, *modulus*. It means measure, image, method. Initially, it meaning was associated with houses, statues and temples construction. Practically all European languages use the model concept associated to images and things. The concept of model is closely associated to the concept of system.

We understand by model a simplified representation of reality. Mathematically we can define a model as:

**Definition 1**

Let be two systems  $A$  and  $B$ . The system  $A$  can be used as model for the system  $B$ , if and only if:

- 1)  $a$  is from certain point of view more simple, comfortable or accessible for researching of the system under study that  $B$ ; mathematically:  $A$  is a subsystem of  $B$ , that is  $A \subset B$ ;

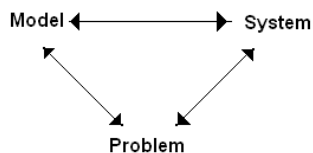

Fig. 1. Relations between system, model and problem

2) certain characteristics, properties or attributes of  $A$  synthesize the properties or behavior of  $B$ ; Mathematically:  $A \rightarrow B$ , in other words  $A$  is a mapping or reflex of  $B$ . This is inspired in the concept of homomorphism;

3) in other senses  $A$  is different of  $B$  (for example: by the material, its form, its dimensions, and others); mathematically:  $A$  is different of  $B$  or  $A \neq B$ ;

4) the knowledge obtained from studying of  $A$  can be transfer, can be applied or can be adapted to  $B$ ; mathematically: Knowledge ( $A$ )  $\rightarrow$  Knowledge ( $B$ ); this idea is inspired on Shtoff definition of model [24].

### **Definition 2**

Let  $S$  be a system. Let  $V$  be a set of elements. Let  $R$  be a set of relations and let  $O$  a set of objectives to reach by the system  $S$ . In these conditions, a system  $S$  can be defined as a set of elements intimately or hardly inter-related with a set of well defined objectives  $O$ . Mathematically the system  $S$  can be defined by:  $S = \{V, R, O\}$ .

Systems like beauty depend on the observer, his interests, wishes and necessities. In this relation a system can be defined in many and different forms according to the objectives, interests and necessities of the observer or designer. Nevertheless, once a set of objectives and interests in function of objects, attributes and relations has been defined, a rigorous analysis, according to defined objectives, restrictions and requirements can be developed. In essence the hierarchic paradox can be formulated in the following form: «the solution to description and formulation problem of any system is possible only under condition that it can be solved the problem of its description as element of a larger and more complex system. At the same time, the solution of the system description problem as element of another more complex and large system is possible on condition that it can be analyzed as part of this system. On the other hand, the knowledge of a system is impossible without the analysis of its parts, for that reason takes place an integrity paradox since: «The optimum of the whole system is not necessarily the optimum of its parts». In another words, the solution of system description problem as integral system is only possible by solving the problem of its division in parts, this puts in evidence the contradiction between system structure and its functions whose solution will guarantee the success or failure of the research or design.

Another scientific problem that appears in the model identification process is associated to feature selection. In modeling process it is necessary to discover and select the most distinguishing qualities, features or attributes. They are closely associated to the model structure. Features selection permits to discover the similarities and differences between different models. The selection of the «best» subset of features from a given set is considered an important and complex scientific problem.

## **Complexity**

A **complex system** is a system composed of interconnected parts that as a whole exhibit one or more properties not obvious from the properties of the individual parts. The complexity of a system can be expressed in function of the number of elements, properties and relations between elements and parts of the system. In this relation, we can define the complexity of an optimization model as a function of its properties, attributes, distinguishing qualities or features (objectives and restrictions). The complexity of a model increases in dependence of the increment of its attributes or features. Between the features of the models we can indicate or mention the following ones: productivity, time available, profit, cost, availability, technical specifications, selling price, land available, source, destination, supply, demand and others

### **Definition 3**

Feature (attribute, symptom, property, parameter, distinguishing quality or characteristic) is an objective or subjective evidence that signs or warns on the existence of something or the membership to certain predefined class or category.

#### **Definition 4**

Object (from Latin - objectum) something physic or mental that can be accepted or caught by the senses or can be known using certain method by the man.

In order to obtain a clear conception of the system behavior, it is necessary to study initially its structure and relations, to define the inputs and outputs, to determine the appropriate objectives, the constraints on what can be done, the possible alternative courses of action, time limits for making decisions, etc. This process of problem formulation is crucial. Determining the appropriate objectives is a very important aspect of problem formulation. In order to identify the problem, it is convenient to formulate a set of questions like as:

- 1) what kind of problem is this?;
- 2) have been known or worked any analogous problems?;
- 3) has the problem some characteristics that remind another problem solved before?;
- 4) what kind of variables can be used in problem solving?;
- 5) what data are known and unknown?; and others.

The essence of the problem formulation stage is to obtain a general conception of the system behavior and its functions. In this stage it is convenient to draw a general system diagram to obtain a better understanding of the system and its functions. One key to successful problem solving in PL is to start at the end.

### **Model Formulation**

After formulating the decision-maker's problem, the next step is to reformulate this problem into a form that is convenient for analysis. The conventional OR approach for doing this is to construct a mathematical model that represents the essence of the problem. A crucial step in formulating the math model is constructing the objective function. This requires developing a quantitative measure of effectiveness relative to each objective. If more than one objective has been formulated for the study, it is then necessary to transform and combine the respective measures into a composite measure of effectiveness. In model formulation stage it is necessary to translate the problem from NL sentences to OR objective function and restrictions. It is necessary to translate a PL problem bit-by-bit and phrase-by-phrase into math expressions. In this stage, the information available is simplified and symbolized by the OR team. Almost all thinking and problem solving that students and engineers develop requires that they handle NL. Often they must perform tasks that also require math manipulations. Language is one of the essential aspects of human behavior. From the first stages to actual stages, language has had a considerable evolution in the history of the humanity. Language has influenced in sensible form in the social and scientific development of human being. The development of writing was a great revolution in human thinking. It created the necessary conditions to record the knowledge and experiences of human groups and peoples from one generation to another. It has contributed in sensible form to develop of history and logics. In its spoken form, language is the main human tool for diagnostic, planning, coordinating and managing the collective activities. Since ancient times, the meaning of sentences and texts had been one of the main problems of NL understanding. This problem is associated with the fact that most words have multiple meanings. Ambiguity would inhibit the system from making the appropriate influences needed to NL understanding. To solve the problem of meaning, it is necessary to use a more precise language. The tools to do this come from logics and involve the use of formally specified representation languages. Many of the first attempts at using computers to process NL concerned the problem of translating from one NL text into another. By translation we understand at the present paper, the operation or process of changing one expression or set of symbols in NL into another expression or set of symbols in formal language or mathematical terms [1–18].

Any general system can be represented by means of a multilevel hierarchical model. Taking into account firstly, the necessity of achieving a better and clear description of the system under study and secondly the necessity of training students in using the system approach method, it was decided to represent the modelling process by means of a multilevel hierarchical approach. A model family able to represent a problem situation (or case) was conceived and designed. In this connection, the problem associated to detail degree for the description of system under study was confronted and carefully analysed. Looking for a better comprehension of an optimal decision making problem two hierarchical levels for the system description were considered. They are named Macromodel and Micromodel. Macromodel gives us a general and integral vision of the system, its operation and behaviour. It presents a higher abstraction level with respect to Micromodel. In the Macromodel are analysed more general objectives, restrictions and decision variables taking into account and processing a little number of details (objectives, restrictions and variables).

In formulating the decision making problem an analysis of the system under study must be made by an OR research team, specialist or student. By means of this analysis, the objectives, restrictions, interactions between variables and other important elements are defined. OR team tries to take into account as broad a scope of objectives as possible. The model expresses the effectiveness of the system under study as a function of a variable's set. Many systems are conceived and designed on hierarchical principle. This concept is based on an adequate description of the following characteristics of the real hierarchical systems through mathematical means:

a) the system contains a set of elements, at least one subprocess may be connected to each element;

b) between the elementary subprocesses a relationship of subordination exists, where if one elementary subprocess is subordinated to another one / even indirectly, then the second subprocess can not be subordinated to the first one;

c) the global goal of the system is an "unification" of a set of local subgoals; (note that an optimum system solution, it's not necessarily the optimum solution for its parts);

The OR designer conceives a system design as consisting of a set of subproblems, the solution to each subproblem leading to a component of the larger system. The components of systems can be considered also as systems. Based on the definition of system and environment it is evident that any given system can be further divided into subsystems. Objects (elements) belonging to one subsystem may be considered as parts of the environment of another subsystem. Consideration of a subsystem, of course, entails a new set of relationship. The behaviour of the subsystem might not be completely analogous with that of the original system.

## **Hierarchy**

Hierarchy is a concept very popular in our times. The concept of Hierarchical Order has many useful applications. In systems design a general objective is implemented by a whole series of successively more detailed models. One of the functions of the designer is to ensure the internal consistency and integration of Models at different Hierarchical Levels. In this way a vague idea of a general System Model is transformed step by step into increasingly exact terms until detailed specifications. Etymologically, the concept «Hierarchy» come from the Greek: Hieros – holy, sacred, celestial, pure and Arche – power. Hierarchical Structure means a distribution of parts of elements of a system in certain order from higher to lower level of description or abstraction. A hierarchical structure of system can be defined, as Mesarovic argued, as a property collection:

1) a set of subsystems distributed vertically;

2) certain action priority or intervention right of higher levels of description with respect to the lower levels it is established or accepted;

3) the work of the higher levels has certain dependence with respect to the activity of lower levels (Fig. 2).

As you can see at Fig. 2, any hierarchical structure has several subsystems distributed vertically, in which higher levels exert influence on lower levels' work by means of concrete actions. In this relation, lower levels are under the influence of higher levels' actions and the external perturbations. Then according with the real effects operated on them the lower levels transmit information to higher levels (feedback). In this connection, they exert (perform) certain influence on the behaviour and the decision making processes at higher levels. Inspired in Bunge hierarchy idea we can introduce the following definition of Hierarchy.

**Definition 5**

$H$  is a hierarchy if and only if, it is an ordered set  $H = \langle X, R \rangle$ , where  $X$  is a non-empty set,  $R$  is a binary relation defined on  $X$ , such that:

- 1)  $X$  has one and only one initial or first element, let be  $a_0$  (i.e.  $H$  have one and only one superior or leader);
- 2)  $a_0$  have certain power of  $R$  with respect to any other member of  $R$  (i.e. all elements of hierarchy are subordinated to the initial element independently of its hierarchical position);
- 3) for any element « $y$ » of  $X$ , except for « $a_0$ » exist an element « $x$ » of  $C$ , such that  $Dxy$  (i.e. each element have only one superior or leader);
- 4)  $R$  is anti-symmetric and transitive relation;
- 5)  $R$  constitutes a power relation.

Model based reasoning approaches should organize model or abstraction levels in a hierarchy in order to facilitate efficiency in the reasoning process. On this basis, several abstraction levels to represent a complex system can be defined. In each level there are a set of variables, concepts, and laws intimately associated or related with defined or selected abstraction level. In Fig. 2 the hierarchical representation of a model family is showed. The blocks of Fig. 2 symbolise the hierarchical and abstraction levels in, which can be divided a general model. The output of any abstraction level is the solution to specific problem and it at once has certain dependence on given parameter at block input. Models have been used to accumulate, classify, organize and relate the knowledge we have about different points of view on Reality. Model constitutes an important tool to reveal, learn and domain the reality. Models are power instruments and means for learning, explaining and taking decisions on the future.

The practical application of OR models can be hampered at times by imperfect knowledge of the necessary data or by a complete lack of data. It is one of those unfortunate facts of life that the numbers that come out of any analysis are related to the numbers that come out of any analysis are related to the numbers that went into the analysis, and not even LP is going to change this. To have confidence in the final result,

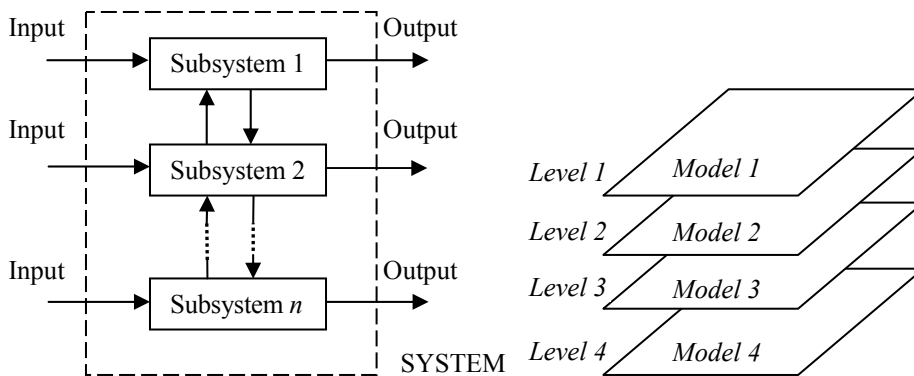

**Fig. 2. Hierarchical System and model family representation**

we must investigate how critically this result depends on the original data. Approximations can be applied to any of components of a model: Variables; Relations; Limitations or constraints Changes in the model can be divided into the following categories: Omitting decision variables; Adding new decision variables; Changing the nature of variables; Modifying the objective function; Changing constraints; Adding constraints; Changing requirements vector. In an educational context modeling is a powerful technique that teaches about some aspect of the world by imitating or replicating it. ORWeb system purpose is to provide teachers and students with a resource for studying complex decision making processes. Its hypermedia and simulation tools provide a resource for study that might otherwise be cost or time prohibitive. Teachers and students can use these hypermedia and simulation tools as examples of real world situations which are best described by a wide variety of mathematical relationships. ORWeb design conception promotes and stimulates the «philosophy of the change», the philosophy of «learning by doing».

### **Learning process**

Teaching and learning processes can be analyzed as a set of activities, which has passed a long and difficult process of improving throughout history. Teaching and learning processes are complex and dynamic. Their fundamental elements are: the teacher and the student. They interchange continuously information and knowledge. Feedback between teacher and student plays an important role in learning process. From one side, the teacher transmits information, knowledge, skills and habits to student. From the other side, the student catches the transmitted information and knowledge, selects and saves it in his memory. In these conditions, we can define the education as a process of interaction between a subject and an object, in which are developed in the object (student) and improved in the subject (teacher) knowledge, skills and habits.

Since ancient times human being has used media to show new ideas, to provide evidence, and to persuade. Learning and teaching media permit:

- 1) optimal comprehension of transmitted information and knowledge,
- 2) improved knowledge control;
- 3) the automation of complex and laborious processes.

Every day, the conflict (contradiction) between the time dedicated to prepare a professional and the information volume is more important and sharp. It is irrational and non-economy solves this contradiction by means of increasing the preparation time. In these conditions, the only one solution consists in changing the approach and improving the efficiency and quality of teaching and learning at universities. At the present moment, computer-based education plays an important role. It presents some advantages:

- 1) the development of modeling and algorithms of subject matter;
- 2) more efficient knowledge transmission;
- 3) the possibility of analyzing and modeling complex and dangerous phenomena;
- 4) more robust visual representation of objects;
- 5) dynamic interaction with the information source, which permits the selection of multiple decision alternatives;
- 6) enhanced the collaborative learning.

The modern world advances step by step to a new Information Society, covering all industrial, scientific, economical, cultural and social areas, particularly the education and health services. New information and communication technologies (**NICT**) are exerting considerable influence on education services. Without any doubt, the benefits that new information and telecommunication technologies may bring to educational services is intimately associated to how they are used and implemented in practice [20].



## Operation Research's Web Site

Discipline Web sites provide a rational way of enhancing previously analyzed problems. In this way, the best traditions of teaching and learning can be introduced creatively in the development of e-learning environments. OR's Web site can be considered to be a virtual classroom where time and distance are suspended. This allows communication from remote points. For example, lectures and their associated slides can be digitally recorded and placed on the Web Page. Students can then listen to these lectures at any convenient time regardless of their location. This allows students who miss a lecture to keep up with the material and provides a valuable study tool. Other examples of the potential uses of Discipline Web sites are the following:

- 1) projects can be distributed from the OR's Web site so students can download them from any computer connected to the Intranet and Internet at any time;
- 2) class handouts can be distributed via the OR's Web site. If changes are needed, they can be updated online and made instantly available to all students;
- 3) e-mail can be used to turn in assignments and return the corrected results;
- 4) consultations hours can be augmented with e-mail;
- 5) in-depth discussions can be held in web-based discussion groups where all students can interchange their modeling experiences. This has the advantage of providing a forum for OR's students;
- 6) testing software and simulations can be placed on the OR's Web site to give students the opportunity to solve problems and practice skills;
- 7) OR's Web site contains papers, thesis works, slides, courseware of each discipline and another complementary materials;
- 8) OR's student's groups will be easier to manage because communication between group members and the instructor is facilitated.

Based on the ideas stated above, the problem that concerns us now is the following:

### How to solve it?

The improvement of the learning process under given conditions must follow the way of strengthening the relationships among production activities and OR learning process. This process must guarantee the development of modeling skills. The student must know the main characteristics of different optimization models and to be able to establish the main differences among them. In the paper, a new software that allows the computer to act as an hypermedia intelligent system on Web is proposed. Using it the students can learn and develop modeling skills in interaction with the Web. The successful design of software requires a rational solution to the following problems:

- 1) how the students can develop their modeling skills?;
- 2) how the students can select the best algorithm? The solution to these problems will determine the specific characteristics of the software. Firstly, can be defined a knowledge system based on rules. This system permits the knowledge and experience of many teachers (experts) to be captured/stored in a computer system. Students requiring it can use this knowledge in order to improve their efficiency in OR problem solving. The purpose of ORWeb is not to replace the OR teachers, but simply to make their knowledge and experience more widely available. Typically, there are more problems to solve than experts available to handle them. ORWeb permits students to improve their modeling skills, to increase their efficiency in problem solving, to improve the quality of their decisions or simply to solve problems when the teacher is not available. Valuable knowledge is a main resource and it often lies with only a few teachers. HIS provide a direct means of applying the teachers' expertise. From our point of view a ORWeb includes modules explicating knowledge about areas: hypermedia problem classifier and generator; teaching domain; expert; student model; debugger; user interface (Fig. 3).

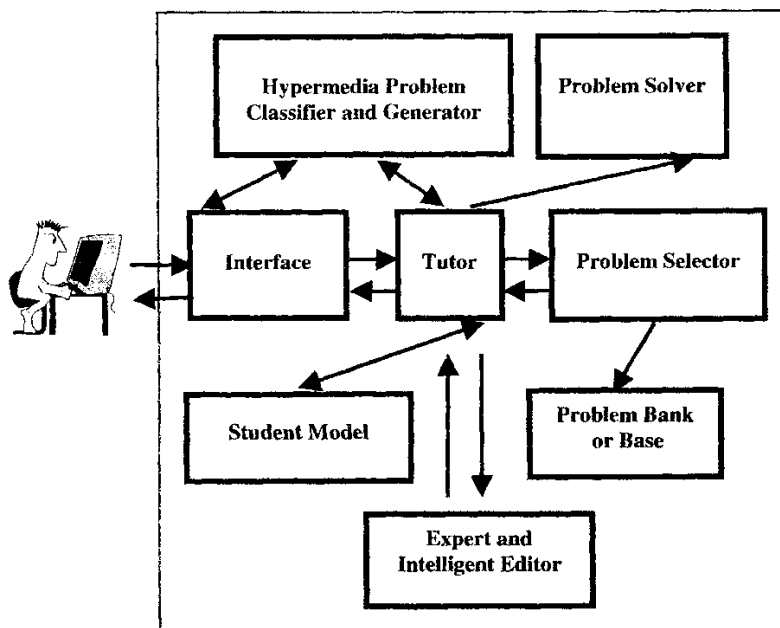

Fig. 3. ORWeb system structure

The ORWeb modules have been described and discussed in the paper titled «Identifying and solving optimization problems by means of Case Based Reasoning in Internet». It has been sent to the present Congress.

### Conclusions

At the present paper, it is proposed a new approach based on Systems Theory, Knowledge based Systems, Case based Reasoning and e-learning in OR model building and optimization problem solving. The scientific problems associated to optimization modeling and problem solving methods by computer are discussed from theoretical and practical point of views. The paper makes a serious contribution to the theory and practice OR field. A basic set of concepts and definitions have been proposed and discussed. They constitute a base for scientific research in the modeling processes and optimization problem-solving. Finally, a new hypermedia intelligent system on Internet is proposed and described. It have been developed a set of software modules that make easy, efficient and comfortable the work of learners, professors and students. Between these modules can be mentioned the following:

- 1) Generator Hypermedia;
- 2) Expert;
- 3) Intelligent Publisher;
- 4) Classifier; and others.

The system has been implemented in .net technology using C# computer language and web services. At the present time, it has been testing and improving at Havana Institute of Technology. Using ORWeb student can analyze different problem situations and solve complex OR problems by means of computer system on Internet. This facility improves the student's relations with the reality and allows him to develop modeling skills. Implemented system stimulates the student active participation in teaching and learning process. It has been developed at Havana Institute of Technology. It has been used by professors and students of several Cuban universities in their projects and thesis works for several years.

## References

1. Ackoff, R. 'Scientific method'. Academic Press, USA, 1962.
2. Descartes, R. "Rules for controlling the reasoning". 1628.
3. Wagner, D. "Fundamentals of Operations Research", Addison-Wesley, 1975.
4. Santamaría, M.A. and Garay Garcell M.A. "Systems Theory in the Mathematical Modeling Teaching". International Systems Journal; Spain Society of General Systems (SESGE); ISSN: 0214-6533. Vol. 4, No. 1–3. Madrid, Spain. Jan-Dec., 1992.
5. Luz y Caballero, José de la. Notas filosóficas de José de la Luz y Caballero. Impugnación a las doctrinas filosóficas de Victor Cousin. Pág. 67–71. Editorial Universidad de La Habana. 1948.
6. Hickman, Frank «Application of A.I. techniques to formulation in Mathematical Modeling»; The Fifth International Conference on Mathematical Modeling in Science and Technology. Berkeley. California. U.S.A. July, 1985.
7. Garay Garcell, Miguel. Iskusvennyi Intellet i Modelirovanie. Escuela Internacional de Computación. Varna. Bulgaria. Junio/1989.
8. Garay Garcell, Miguel; "Artificial Intelligence and Mathematical Modeling;"Seminary of Artificial Intelligence. Technical University of Helsinki; Helsinki. Finland. Octubre/1990.
9. Garay Garcell, Miguel. La inteligencia artificial en la enseñanza de la Modelación Matemática. II Congreso Mundial de Educación y Entrenamiento en Ingeniería y Arquitectura. Palacio de Convenciones. Ciudad de La Habana. Cuba. Septiembre/1991.
10. Maxrov, N.V. A.A Modin, and E.G., Yakovenko, (1974) "Design parameters on modern MIS in enterprises", chapter 3, pp 39–71 Ed. Nauka. Moscow.
11. Garay M.A, C. Sotolongo (1982), "Método para la clasificación de Empresas por computadoras." Revista Ingeniería Industrial. Junio/1982. ISPJAE, MES. La Habana. Cuba.
12. Garay Garcell, Miguel (1991) "La inteligencia artificial en la enseñanza de la Modelación Matemática". II Congreso Mundial de Educación y Entrenamiento en Ingeniería y Arquitectura. Palacio de Convenciones. Ciudad de La Habana. Cuba. Septiembre/1991.
13. Sandi Pinheiro, M., Lozano Reyes, F., Garay Garcell, M.A., (1999) "A software tool for classification of objects and word problems in hypermedia intelligent tutoring systems", Journal of Computer Applications on Engineering Education, Vol. 8, No. 3/4 , 2000 (CAE 20-264) pages 235–239. Ed. by John Wiley & Sons. November, 2000. USA. Online ISSN: 1099-0542 and Print ISSN: 1061-3773. Electronic Address: <http://www.interscience.wiley.com/jpages>.
14. Garay Garcell M. A., Sandi Pinheiro M. (2001) «Clustering methods in Hypermedia intelligent tutoring systems «, Conference proceedings of «The 2001 International Conference on Internet Computing». Las Vegas, Nevada. USA. June 25–29, 2001.
15. Garay Garcell M.A. , Sandi Pinheiro M. (2001) "On Classification Problems in Hypermedia Intelligent Tutoring Systems" pp. III–VII. ISBN: 84-931 933 – 9 – 0. SIT' 2001. Symposia of Informatics and Telecommunications. A Coruña, Spain, September 12–14th, <http://www.lfeia.org/sit01>.
16. Garay Garcell, M.A. , Sandi Pinheiro M , Teixeira, V.(2002) "Clustering and Decisions Methods in Hypermedia intelligent tutoring systems", European Meeting on Cybernetics and Systems Research, EMCSR 2002, University of Vienna organized by: Austrian Society for Cybernetic Studies and International Federation for System Research, Vienna, Austria, April 2–5, 2002.

17. Garay Garcell, M.A., Sandi Pinheiro M, Teixeira, V. (2002) "Multilevel Systems Approach in hypermedia intelligent tutoring systems", European Meeting on Cybernetics and Systems Research, EMCSR 2002, University of Vienna organized by: Austrian Society for Cybernetic Studies and International Federation for System Research, Vienna, Austria, April 2–5, 2002.

18. Garay Garcell, M.A., (2004), "A hypermedia intelligent tutoring system for Operations Research Teaching," OR Insight. Volume 17, Issue 2. March – June 2004, pp. 23–27. United Kingdom.

19. Garay Garcell M.A., (2004) «System Approach and Modelling Teaching». Conference proceedings of «The 2004 International Conference on Artificial Intelligence» (IC-AI'04: June 21–24, 2004, Las Vegas, Nevada, USA; <http://www.world-academy-of-science.org>. Las Vegas, Nevada, USA. July, 2004.

20. Garay Garcell, M.A. et al., "Development of E-learning and E-healthcare Community Network for Cuba and the Caribbean Countries". Book: In *Global Peace Through The Global University System*, 2003 Ed. by T. Varis, T. Utsumi, and W. R. Klemm., University of Tampere, Hämeenlinna, Finland.

21. Comenius, J. A. (1657), *Obras Completas*. Editorial "Pueblo y Educacion" (1985). La Habana.

22. Klir, G. *Cybernetic Modeling*, Iliffe, London. 1967

23. Klir, G. *Architecture of Systems Problem Solving*, with D. Elias, Plenum Press, New York, 1985.

24. Shtoff, V. *Modeling and Philosophy*, Leningrad, 1968.

25. Simon, Herbert (1983), "Why should machines learn? In Michalski, R., J.O. Carbonell and T.M. Mitchell, "Machine Learning: An Artificial Intelligence Approach", Vol. 1, Palo Alto, C.A. Tioga, 1983.

26. Bacon, F. (1620). *Novum Organum*

27. Abbagnano, Nicola, „Diccionario de Filosofia“. E.R. ICL. 1963, pp. 496.

28. Hall, Arthur D., "System Engineering," Ch. 12, *The Casuistic Theory of value*. Pp. 321–322. New York 1962.

---

## Определение и решение оптимизационных задач в сети

Мигель А. Гарай Гарселл, Лиз У. Мартинез Дельгадо,  
Лейдер Аргуэль Торес, Ариэль Каstellанос Айзак

**Ключевые слова и фразы:** Интернет; определение; оптимизация.

**Аннотация:** В последнее время проектирование и реализация моделей с использованием компьютерных технологий и методов находится в центре внимания многих научных работ в области искусственного интеллекта, исследования операций, систем поддержки принятия решений и систем менеджмента. Предлагается новый метод конструирования моделей, базирующийся на применении системного подхода, систем, основанных на знаниях, доказательной аргументации и электронном обучении. С точки зрения теории и практики обсуждаются проблемы, связанные с созданием оптимизационных моделей с помощью компьютера. Кроме того, предлагается новая гипермедийная интеллектуальная Интернет-система. Ее цель помогать обучающимся (профессионалам и студентам) в конструировании и реализации моделей. Принимая во внимание данную концепцию, была разработана новая электронная обучающая платформа для преподавания и изучения исследования операций. Система была реализована с помощью .net-технологии с использованием языка программирования С и сетевых услуг. В настоящее время она проходит апробацию и усовершенствование в Институте Технологий Гаваны.

## **Bestimmung und Lösung der Optimisationsaufgaben in der Netz**

**Zusammenfassung:** In der letzten Zeit befindet sich die Projektierung und die Realisierung der Modelle mit der Nutzung der Computertechnologien und der Methoden im Zentrum der Aufmerksamkeit vieler wissenschaftlicher Arbeiten auf dem Gebiet des künstlichen Intellekts, der Forschung der Operationen, der Systeme der Unterstützung der Annahme der Beschlüsse und der Systeme des Managements. Im vorliegenden Artikel wird die neue Methode des Konstruierens der Modelle, die sich auf der Anwendung des Systemherangehens, den auf dem Wissen gegründeten Systemen, der überzeugenden Argumentation und der elektronischen Ausbildung stützt, vorgeschlagen. Vom Gesichtspunkt der Theorie und der Praxis werden die Probleme, die mit der Schaffung der Optimisationsmodelle mit Hilfe des Computers verbunden sind, besprochen. Außerdem wird das neue hypermedia intellektuelle Internet - System vorgeschlagen. Sein Ziel ist die Hilfe den Auszubildenden (den Spezialisten und den Studenten) im Konstruieren und der Realisierung der Modelle. Beachtend die gegebene Konzeption, war die neue elektronische auszubildende Plattform für das Unterrichten und das Studium der Forschung der Operationen entwickelt. Das System war mit Hilfe .net-Technologie mit der Nutzung der Sprache des Programmierens C und der Netzdienstleistungen verwirklicht. Zur Zeit vergeht sie die Approbation und die Vervollkommnung im Institut der Technologien Havannas.

---

## **Identification et solution des problèmes d'optimisation dans l'Internet**

**Résumé:** Ce dernier temps la conception et la réalisation des modèles avec l'utilisation des technologies et des méthodes informatiques se trouvent au centre de beaucoup d'oeuvres scientifiques dans le domaine de l'intelligence artificielle, de l'étude des opérations et des systèmes du soutien de la prise des solutions et des systèmes du management. Dans le présent article est proposée une nouvelle méthode de la construction des modèles basés sur l'application d'une approche systémique, des systèmes fondés sur les connaissances, sur l'argumentation prouvée et sur l'enseignement one-line. Du point de vue de la théorie et de la pratique sont discutés les problèmes liés à la création des modèles d'optimisation à l'aide de l'Internet. De plus, est proposé un nouveau système intellectuel hypermédia de l'Internet. Son but est d'aider aux enseignants (professionnels et étudiants) dans la construction et la réalisation des modèles. Compte tenu de cette conception, est élaborée une nouvelle plate-forme électronique pour l'enseignement et les études des opérations. Le système a été réalisé à l'aide de Net-technologie avec l'emploi de la langue de la programmation C et des services du réseau. Actuellement il est testé et perfectionné à l'Institut technologique de la Havane.

---